

TECNICAL CATALOGUE

C026 2020

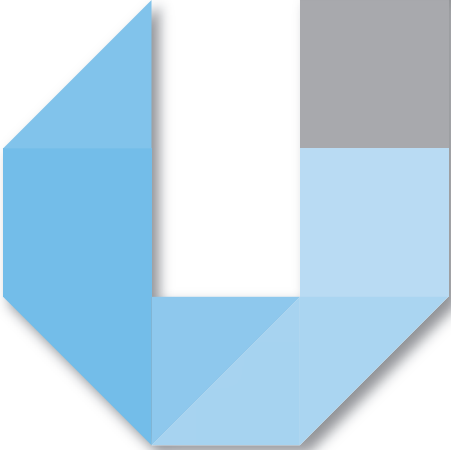

aircom
PIPING SYSTEM

AIR IS OUR FUTURE

QUICK
QUICK

EASY
EASY

RELIABLE
RELIABLE



Italia

CERTIFICATO

Nr. 50 100 4121 - Rev.006

Si attesta che / This is to certify that

IL SISTEMA QUALITÀ DI
THE QUALITY SYSTEM OF



AIRCOM S.r.l.

SEDE LEGALE E OPERATIVA:
REGISTERED OFFICE AND OPERATIONAL SITE:

**VIA TRATTATO DI MAASTRICHT SNC
IT - 15067 NOVI LIGURE (AL)**

È CONFORME AI REQUISITI DELLA NORMA
HAS BEEN FOUND TO COMPLY WITH THE REQUIREMENTS OF

UNI EN ISO 9001:2015

QUESTO CERTIFICATO È VALIDO PER IL SEGUENTE CAMPO DI APPLICAZIONE
THIS CERTIFICATE IS VALID FOR THE FOLLOWING SCOPE

Progettazione e fabbricazione di tubi, raccordi ed accessori in materiale termoplastico e tecnopolimero per la distribuzione di aria compressa e fluidi; progettazione di raccordi in alluminio. Commercializzazione di tubi in alluminio, valvole e accessori per la distribuzione di aria compressa (IAF 14, 29)

Design and manufacturing of pipes, fittings and accessories in thermoplastic and technopolymer material for compressed air and fluid distribution; design of aluminium fittings. Trade of aluminium pipes, valves and accessories for compressed air distribution (IAF 14, 29)



SGQ N° 049A

Membro degli Accordi di Mutuo Riconoscimento
EA, IAF e ILAC
Signatory of EA, IAF and ILAC Mutual
Recognition Agreements

Per l'Organismo di Certificazione
For the Certification Body
TÜV Italia S.r.l.

Validità / Validity

Dal / From: 2018-12-04

Al / To: 2021-12-03

Data emissione / Printing Date

Andrea Coscia
Andrea Coscia
Direttore Divisione Business Assurance

2018-12-04

PRIMA CERTIFICAZIONE / FIRST CERTIFICATION: 2004-03-16

"LA VALIDITÀ DEL PRESENTE CERTIFICATO È SUBORDINATA A SORVEGLIANZA PERIODICA A 12 MESI E AL RIESAME COMPLETO DEL SISTEMA DI GESTIONE AZIENDALE CON PERIODICITÀ TRIENNALE"

"THE VALIDITY OF THE PRESENT CERTIFICATE DEPENDS ON THE ANNUAL SURVEILLANCE EVERY 12 MONTHS AND ON THE COMPLETE REVIEW OF COMPANY'S MANAGEMENT SYSTEM AFTER THREE-YEARS"

TABLE OF CONTENTS

INTRODUCTION to AIRCOM Product Range

ANNEX A

Assembly Instructions

ANNEX B

Quick Line Aluminium - Technical Data Sheets

ANNEX C

Quick Line HR-Polymer - Technical Data Sheets

The information contained in these documents is based on science and knowledge and represents the current state-of-the-art. The information, data and images of Aircom Srl products shown herein are provided without obligation and are for guidance purposes only. We reserve the right to make technical modifications without prior notice. We recommend that users always check the suitability of products for the applications involved. The reproduction or partial reproduction of these documents is forbidden without written consent from Aircom Srl.

All rights reserved.
(S. E. & O.)

PRODUCT RANGE

Constant development, expansion and changes to production layouts in factories and the evolution of production technologies, especially towards automation, calls for compressed air distribution systems that are appropriately sized and easily modified.

The AIRCOM QUICK LINE system was designed and created specifically for constructing compressed air and pressurised fluid distribution systems.

QUICK LINE ALUMINIUM AND HR-POLYMER

Choosing quality compressed air products means eliminating the typical costs incurred in managing the obsolete systems that are still in use. It also lets buyers choose from a huge range with the knowledge that such quality products have been fully tested and certified in compliance with current legislation.

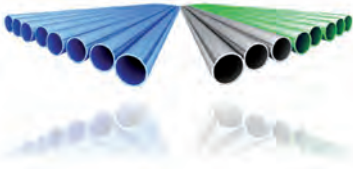

Aluminium Pipe



Aluminium Fittings



HR-Polymer Fittings

Diameter Ø

16 - 20 - 25 - 32 - 40
50 - 63 - 80 - 110 - 168,3 mm

Materials

AN AW 6060 T6 aluminium alloy
with internal and external
fluotitanation treatment

Markings

- Product line
- External Dia. - Internal Dia.
- P. Max in BAR
- P. Max in PSI
- Production batch

Diameter Ø

20 - 25 - 32 - 40
50 - 63 - 80 - 110 mm

Nut & Body

Aluminium alloy EN-AB 46100
Standards UNI-EN 1676

Clamping ring

Stainless steel X10CrNi18-8
UNI-EN 10088

Gasket

NBR 70
ISO 1043

Conical ring

- HR Polymer 6
- ISO 1043

Diameter Ø

16 - 20 - 25 - 32
40 - 50 - 63 mm

Nut & Body

Alloy HR Polymer
Standards ISO 1043

Clamping ring

Stainless steel X10CrNi18-8
UNI-EN 10088

Gasket

NBR 70
ISO 1043

Marking

- Diameter
- Date

LARGE SIZES

The new 168,3 mm (6") family, is the largest diameter size in AIRCOM, at present.

A perfect solution for compressor rooms, large piping networks and distribution mains!

ACCESSORIES

The vast range of accessories will allow you, not only to operate in complete safety, but also to speed up installation work and plant maintenance. The Accessories range include a set of equipment specifically designed for the Quick Line Aluminium, the Quick Line HR-Polymer and the Evo Line systems, resulting in rapid, professional assembly.

Thanks to the new multilayer pipe, you can shape pipe sections in problematic areas, overcoming obstacles in the easiest, fastest way possible. Assembly is done professionally and rapidly with the complete range of screw nut wrenches and dedicated tools.



Large sizes 80 - 110 mm



Large sizes 168,3 mm (6")



Common Accessories

Diameter Ø

80 - 110 mm

Nut & Body

Aluminium alloy EN-AB 46100
Standards UNI-EN 1676

Tightening ring

Stainless steel X10CrNi18-8
UNI-EN 10088

Gasket

NBR 70
ISO 1043

Conical ring

- HR Polymer 6
- ISO 1043

Diameter Ø

168,3 mm

Fittings Body

Aluminum
ASTM B-26, 356-T6 alloy.

Coupling

Galvanized ductile iron
ASTM A 536, Grade 65-45-12.

Gasket

Nitrile

Diameter Ø

16 - 20 - 25 - 32 - 40 - 50
63 - 80 - 110 - 168,3 mm

Brackets

PP
Polypropylene

Quick Line nut wrench

PA6
Polyamide 6

Multilayer pipe

PE-RT (internal layer)
Adhesive layer
Aluminium layer overlapped
and ultrasonic welded
Adhesive layer
PE-RT (external layer)

FIELDS OF APPLICATION

COMPRESSED AIR

The AIRCOM QUICK LINE system was designed mainly for the transportation and distribution of COMPRESSED AIR at pressures of up to 16 bar.

The wide range of products available means that plant equipment units can be created that start from the air production and treatment unit then go on to the distribution loop and all the peripheral take-offs. A series of special items quickly and efficiently deals with all the specific problems of installation normally associated with compressed air.

The AIRCOM QUICK LINE system integrates perfectly with the whole AIRCOM product line, such as the CLASSIC line.

The ease and speed with which the Quick Line system can be assembled is the direct result of innovative technology which allows the instant connection of components to aluminium pipes.

This technology takes into account all diameters and all types of joints and fittings to offer the user safety from any potential stress.

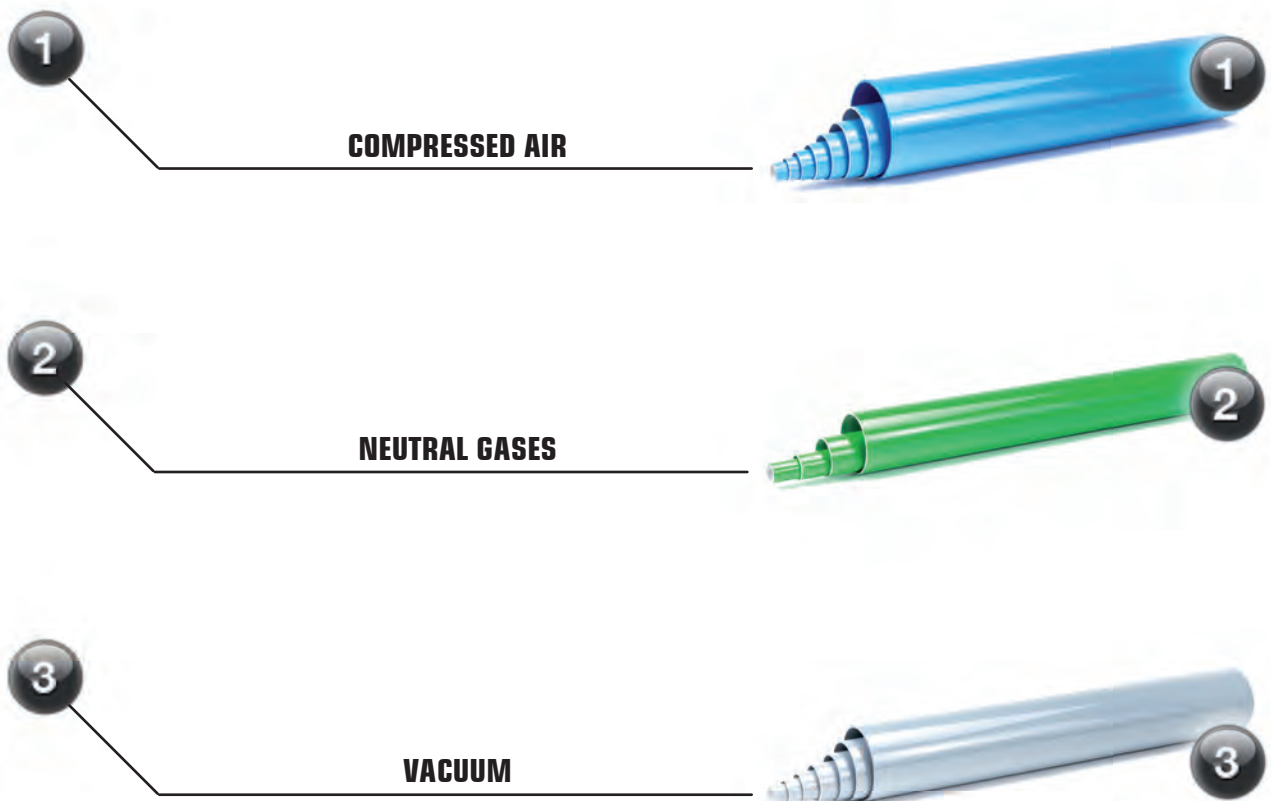

DISTINCTIVE PIPE COLOURING SYSTEM

The colour identification system for bare pipes and ducting is described in detail in UNI 5634 - 97.

Fluid	ID color	RAL code
Neutral gases		6032
Vacuum		9006
Compressed air		5012

SAFETY

REACTION TO FIRE

All AIRCOM components are self-extinguishing and do not propagate flames
Pipes, fittings:

EN13501-1:2007 + A1:2009
EN ISO 11925-2:2010
EN ISO 13823:2010

SYSTEM VERSATILITY

AIRCOM products have been specifically studied and designed to create complete systems for the distribution of compressed air and pressurised fluids. Thanks to their versatility, they can be connected to already existing plant units.

CE CONFORMITY

All our products comply with 97/23/EC

TEN-YEAR GUARANTEE

In line with high quality performance of its product range, AIRCOM offers a ten-year guarantee on materials.

To read the Terms of Cover of the guarantee, refer to the Technical Catalogue.



AIRCOM TECHNOLOGY - Quick, Easy & Reliable!

A modern, high technology & high performance systems, flexible in its application, to expand and grow together with your factory! AIRCOM is the only producer offering a complete range of systems differentiated by features and performance. Innovative technology at the heart of AIRCOM fittings, enables rapid and easy assembly: quick connection of components to the aluminium pipe.

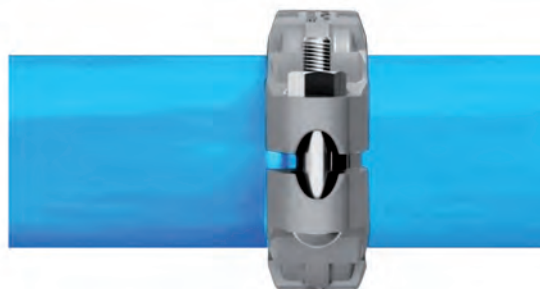
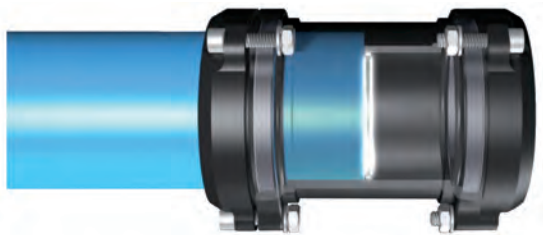
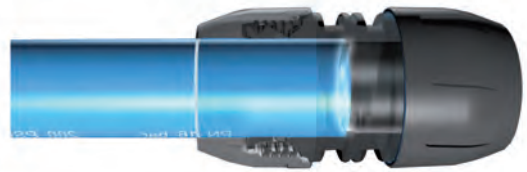
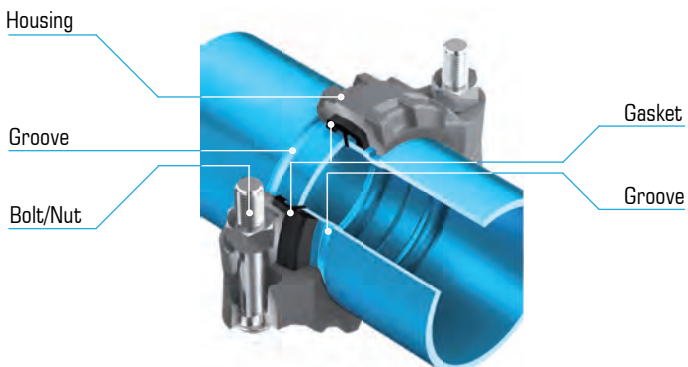
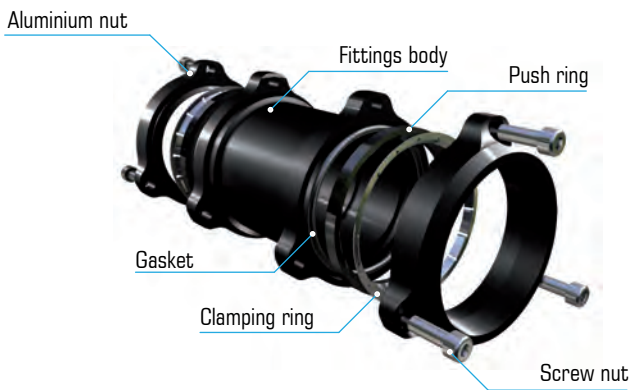
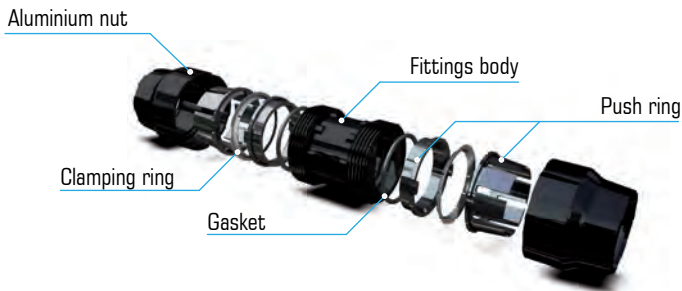
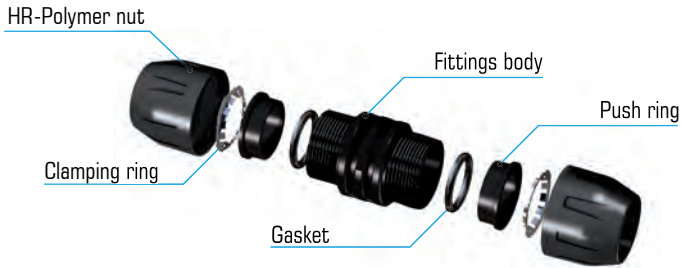

QUICK LINE SYSTEM

A twin, modular piping system with outstanding features in terms of speed and ease of assembly:

- > Quick Line Aluminium System: aluminium pipes with aluminium fittings
- > Quick Line HR-Polymer System: aluminium pipes with HR-Polymer fittings

The peculiar, great insertion depth of pipe inside of fittings contributes to a more reliable alignment of pipes and fittings, improved structural cooperation and stronger grip on the pipe.

QUICK LINE HR-POLYMER

A complete system of aluminium pipes with fittings in HR-Polymer.

The HR-Polymer fittings come in following diameters:

16-20-25-32-40-50-63 mm

The entire range of threaded fittings is available both with GAS and NPT thread.

QUICK LINE ALUMINIUM

A complete system of pipes and fittings in aluminium.

The die-cast aluminium fittings come in following diameters: **20-25-32-40-50-63-80 mm**

The entire range of threaded fittings is available both with GAS and NPT thread.

QUICK LINE ALUMINIUM 110 mm (4")

A complete range of pipes and fittings in aluminium, diameter size **110 mm**

Same technology as the a smaller sizes but adapted to the large size of 110 mm / 4".

The entire range of threaded fittings is available both with GAS and NPT thread.

A perfect solution for medium-size compressor rooms, large piping networks and distribution mains!

QUICK LINE ALUMINIUM 168.3 mm (6")

A complete range of aluminium pipes with special fittings, diameter size **168.3 mm (6")**

Pipes coming with already pre-grooved ends.

The entire range of threaded fittings is available both with GAS and NPT thread.

A perfect solution for compressor rooms, large piping networks and distribution mains!

SPECIFICATIONS FOR QUICK LINE ALUMINIUM & POLYMER

The fittings and joints allow for the creation of systems that can resolve the problems and requirements associated with more complex plant units.

Speed of installation, a perfect airtight seal, significant mechanical resistance and efficiency over time are the hallmark of AIRCOM products.



CORROSION

The hot electro-plating system used for aluminium alloy pipes eliminates problems of corrosion and degradation of internal and external surfaces. It means that the product has a guaranteed lifespan of at least 50 years under normal conditions of use.



MECHANICAL BEHAVIOUR

The materials used in the system guarantee excellent performance characteristics in terms of mechanical resistance, internal pressure and resistance to external impacts. Pipes can also cope with violent impacts and shock with no danger.



ULTRAVIOLET RAYS

Aluminium does not suffer when exposed to ultraviolet rays meaning that it can be used both indoors and out.



FIRE RESISTANCE

Aluminium has excellent fire resistance properties and neither feeds nor propagates fire.



FLOW RATE

The AIRCOM QUICK LINE system offers excellent flow rates per diameter due to the low coefficient of friction, the wide cross section of the pipes and the absence of internal hindrances or areas where the pipes becomes narrower.



SIZE CHARACTERISTICS AND STANDARDS

All the components in the AIRCOM QUICK LINE system comply with national and international standards regarding pipes for pressurised fluids.



COMPATIBILITY WITH OILS FOR COMPRESSORS

Aluminium, like the technopolymers from which the AIRCOM QUICK LINE system is made, do not present any particular problems on contact with lubricants for compressors.

MATERIAL CHARACTERISTICS

MATERIALS USED AND REFERENCE STANDARDS



QUICK LINE	MATERIAL	REFERENCE STANDARDS
Aluminium pipe	EN AW 6060 T6 aluminium alloy with internal and external fluoritanation treatment	UNI-EN 755-2
Ring nuts up to dia. 50 PA	Polyamide 6 Diam.16 - 63	ISO 1043
Ring nuts larger than dia. 50 AL	EN-AB 46100 aluminium alloy	UNI-EN 1676
Bodies up to dia. 50 PA	Polyamide 6	ISO 1043
Bodies larger than dia. 50 AL	EN-AB 46100 aluminium alloy	UNI-EN 1676
Push ring	Polyamide 6	ISO 1043
Clamping ring	X10CrNi18-8 stainless steel	UNI-EN 10088
Gaskets	NBR 70 (Viton® on request)	ISO 1043
Flexible hoses	-	-
Quick Line ball valves	-	-
Aluminium bodies and joint	EN-AB 46100 aluminium alloy	UNI-EN 1676
Brass bodies and joint	CW 617N brass alloy	UNI-EN 12165
Threaded inserts	Polyamide 6	ISO 1043
Applique bodies AL	EN AW 6063 T66 aluminium alloy	UNI-EN 755-2
Quick branch droplet bodies	Polyamide 6	ISO 1043
Brackets	Polypropylene	ISO 1043
M8 screw-bolts	Galvanised steel	UNI-EN-ISO 4032
Spacers	Polypropylene	ISO 1043
Bracket systems	Galvanised steel	-

TYPICAL PHYSICAL AND MECHANICAL FEATURERS OF ALUMINIUM EN AW 6060 T6 ALUMINIUM ALLOY



CHARACTERISTIC	VALUE	NOTES
Metallurgical state	T6	-
Density	2,7 Kg/dm ³	-
Elastic modulus	69 KN/mm ²	-
Coeff. of thermal expansion	23 μ/m/°C	from 20° to 100°C
Thermal conductivity	200 W/(m·K)	a 20°C
Specific heat	880 ÷ 900 J/(Kg·K)	from 0° to 100°C
Melting point	600 ÷ 660 °C	-
Tensile strength Rm	190 N/mm ²	Minimum
Yield strength Rp	150 N/mm ²	Minimum
Elongation A %	8	Minimum
Elongation A (50mm) %	6	Minimum



DESIGN AND QUALITY CONTROL

AIRCOM products come under the aegis of Made in Italy, and product quality is therefore of the very highest standard. The Company has numerous departments dedicated to specific activities for the Quality Control.

QUALITY CONTROL TEST

- Mould controls
- Size controls / Size tests
- Pneumatic leak tests at **PN 16 bar**
- Resistance factor 4
- Polymer ageing tests at **64 bar**
- Resistance tests at up to **120 bar**
- Pressure tests with compressed air
- Pressure tests with water

Product conforms or does not conform before being released to market.

COMPRESSED AIR PURITY CLASSES

The levels of purity for each contaminant are usually shown separately; this document combines all three contaminant in an easily read single table.

PURITY CLASSES	Solid particulate				Water		Oil
	Number of particles per m ³			Concentration of mass mg/m ³	Dewpoint	Liquid g/m ³	Total oil (aerosol, liquid and vapour)
	0.1 – 0.5 μm	0.5 – 1 μm	1 – 5 μm				mg/m ³
0	As specified by the user or by the equipment supplier is more rigid than Class 1						
1	≤ 20,000	≤ 400	≤ 10	-	≤ - 70°C	-	0.01
2	≤ 400,000	≤ 6,000	≤ 100	-	≤ - 40°C	-	0.1
3	-	≤ 90,000	≤ 1,000	-	≤ - 20°C	-	1
4	-	-	≤ 10,000	-	≤ + 3°C	-	5
5	-	-	≤ 100,000	-	≤ + 7°C	-	-
6	-	-	-	≤ 5	≤ + 10°C	-	-
7	-	-	-	5-10	-	≤ 0.5	-
8	-	-	-	-	-	0.5 - 5	-
9	-	-	-	-	-	5 - 10	-
10	-	-	-	> 10	-	> 10	> 10

EQUIVALENT LENGTHS AND SELECTION OF THE RIGHT DIAMETER

The table below shows the sizes in metres of every fittings.

The equivalent length that comes from the sum of the joints is then added to the average length of pipe used.

Every fittings used on the plant will slow the flow of air to a certain extent depending on its internal geometry.

To allow the size of plant units to be correctly calculated, AIRCOM have drawn in the table below to show lengths in metres and the values relating to any reduction in speed of the flow of air caused by every type of fittings and main accessory.

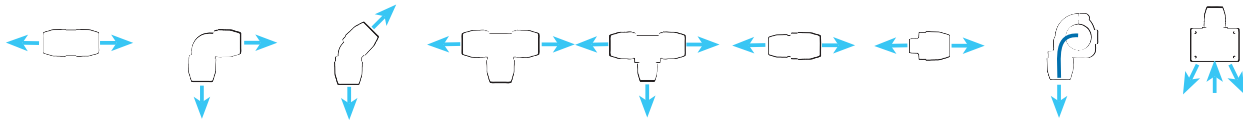

	Couplings	90° Elbows	45° Elbows	Tee	Reduction Tee	Reduction	Nipple	Droplet	Manifolds
16	0,1	0,7	-	0,1	-	-	0,1	-	0,8
20	0,2	1,2	1	0,2	1,3	-	0,2	-	1,2
25	0,2	1,5	1,2	0,3	1,8	0,5	0,2	1,8	1,5
32	0,3	2	1,3	0,3	2,4	0,6	0,3	2,4	-
40	0,3	2,4	1,6	0,4	3	0,7	0,3	3	-
50	0,4	3	2	0,4	4	1	0,4	4	-
63	0,5	3,5	2,5	0,5	4,5	1,5	0,5	4,5	-
80	0,7	4,8	-	0,7	5,5	2	0,7	5,5	-
110	0,8	6	-	0,8	6,5	2,5	-	6,5	-
168,3	-	3	1,5	3	-	-	-	7,6	-

LENGTH

Once we know the operating pressure, the rate of flow required and the distance between the compressor and the furthest take off point and taking into consideration the equivalent lengths in metres, we can now calculate the correct sizing of the plant unit.

SELECTING THE OPTIMAL PIPE FOR THE MAIN LOOP

The values refer to a pressure of 8 bar and a maximum pressure drop of 5%

		DISTANCE BETWEEN THE COMPRESSOR AND THE FURTHEST TAKE OFF POINT (in m)									
Nm ³ /h	Nl/min	25	50	100	150	200	300	400	500	1000	
36	600	16	16	20	20	25	25	25	25	32	
54	900	16	20	20	25	25	25	32	32	40	
72	1200	20	25	25	25	32	32	32	32	40	
105	1750	25	25	32	32	32	40	40	40	50	
150	2500	25	32	32	32	40	40	40	50	50	
210	3500	32	32	40	40	40	50	50	50	63	
270	4500	32	32	40	40	50	50	50	50	63	
360	6000	40	40	40	50	50	50	63	63	63	
510	8500	40	40	50	50	50	63	63	63	80	
720	12000	50	50	50	63	63	63	80	80	80	
1080	18000	50	63	63	63	80	80	80	80		
1260	21000	63	63	63	80	80	80	80			
1860	31000	63	80	80	80	80					
2700	45000	80	80	80							
6000	100000	80	110	110							
8100	135000	110	110								
10350	172500	168,3	168,3								
15780	263000	168,3	168,3								
23700	395000	168,3									

If the instant flow rate is equal to or less than that generated by the compressor and the loop is shorter than recommended for a determined pipe diameter, the pressure drop will not exceed 5%. We recommend using larger diameter pipe for potential future developments and to avoid the negative effects caused by the excessive speed of compressed air inside the line.

FLOW RATE AND PRESSURE DROP TABLES

The table below shows the maximum recommended flow rate to prevent excessive speed inside the pipe which can lead to:

- a. an increase in turbulence and subsequent pressure drop;
- b. noise which may exceed the legally allowed limits;
- c. the vaporisation of any condensation present and its spread within the plant unit.

FLOW RATE TABLES

(based on a length of 30 metres)

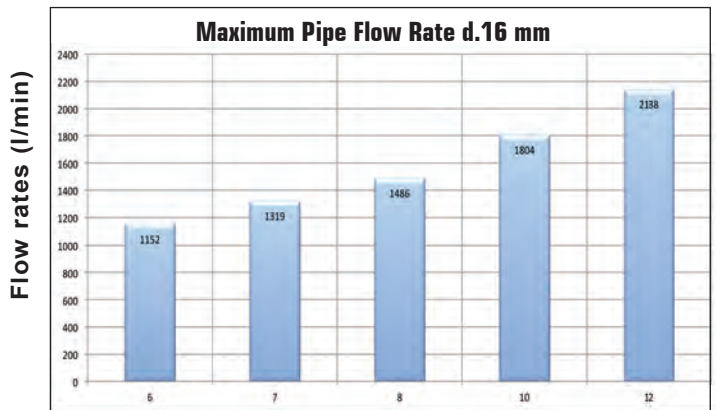

- Table 1a

Bar

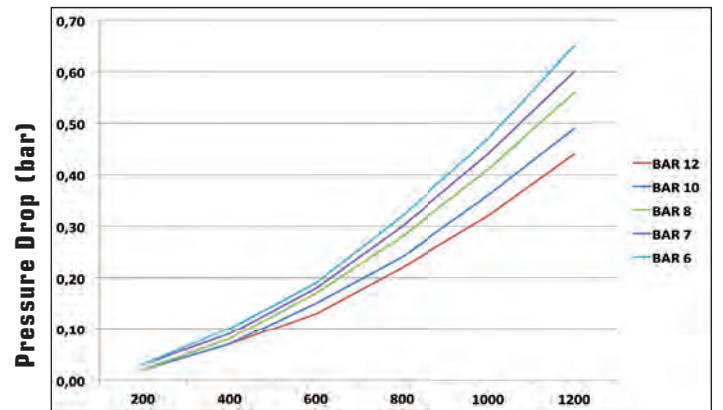

- Table 1b

Consumption lt/min

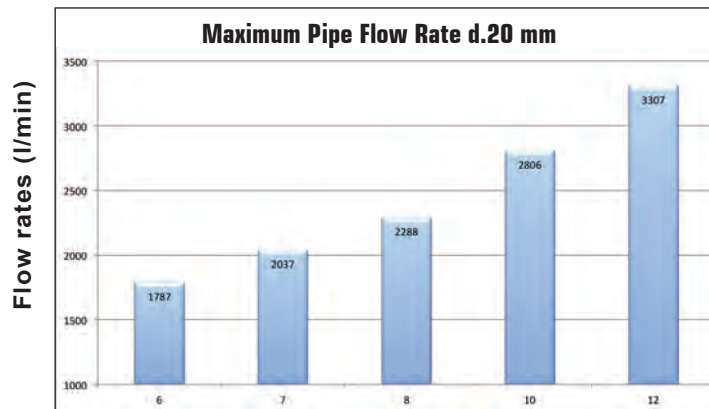

- Table 2a

Bar

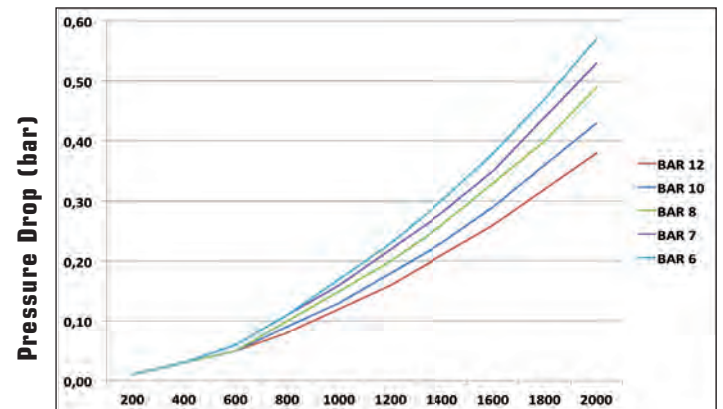

- Table 2b

Consumption lt/min

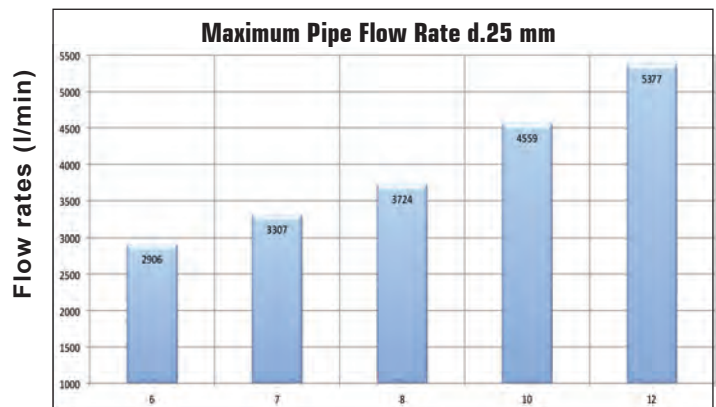

- Table 3a

Bar

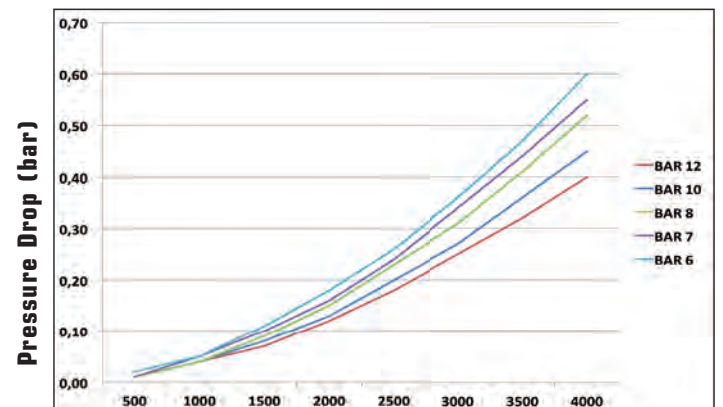

- Table 3b

Consumption lt/min

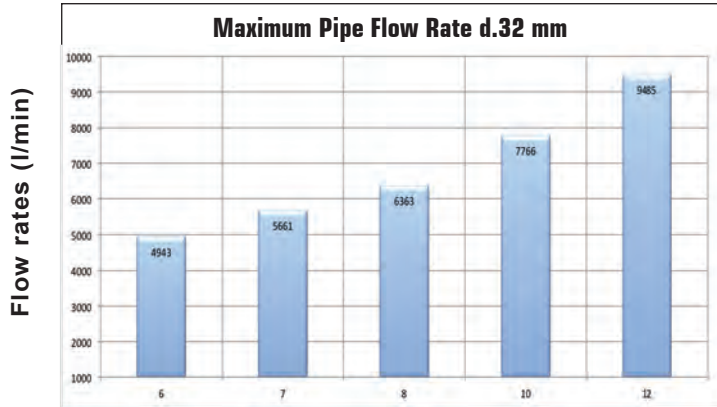

- Table 4a

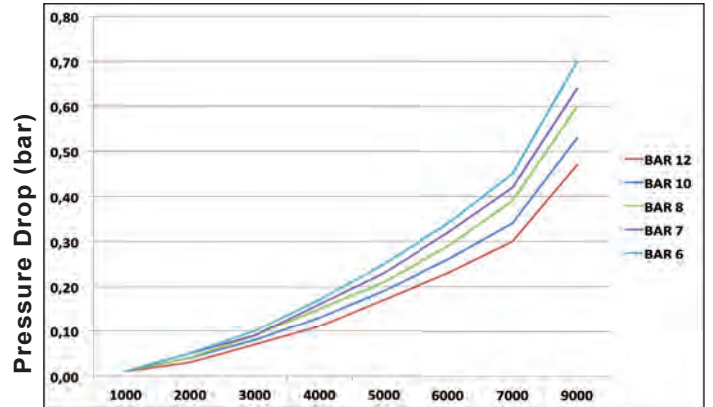

- Table 4b

Consumption lt/min

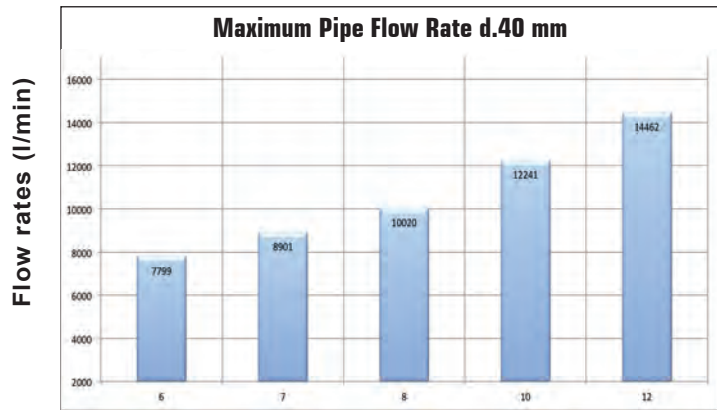

- Table 5a

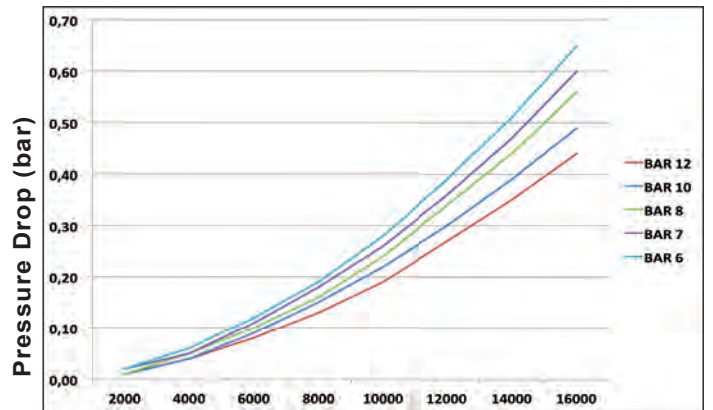

- Table 5b

Consumption lt/min

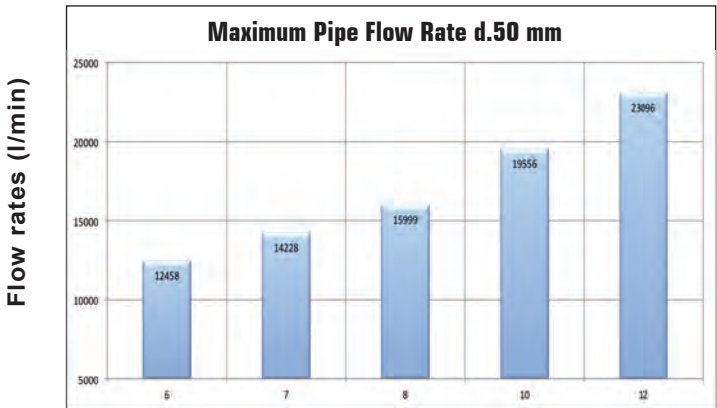

- Table 6a

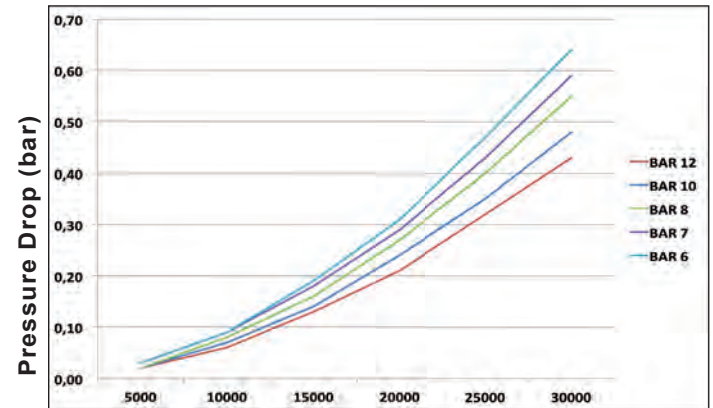

- Table 6b

Consumption lt/min

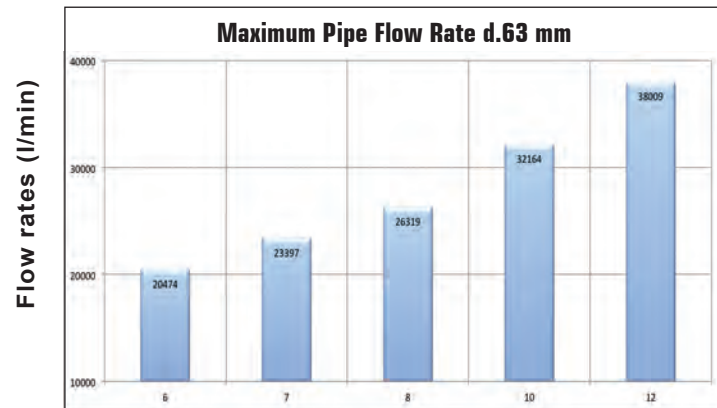

- Table 7a

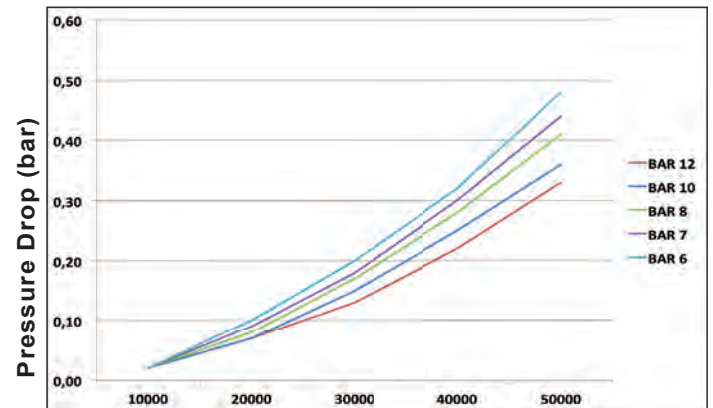

- Table 7b

Consumption lt/min

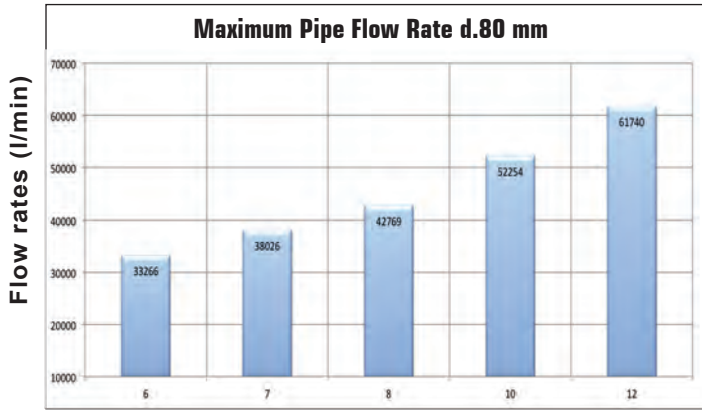

- Table 8a

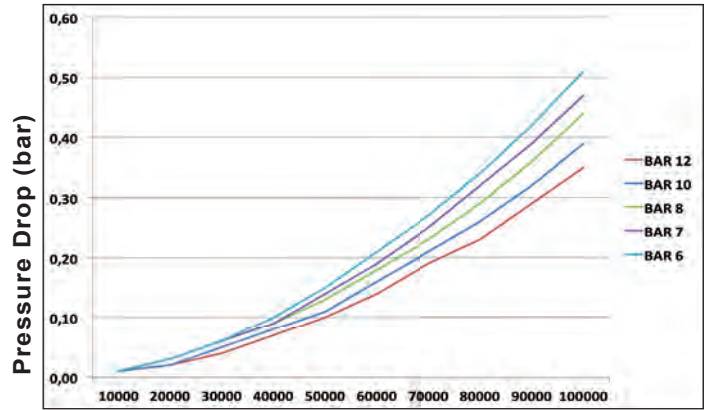

- Table 8b

Consumption lt/min

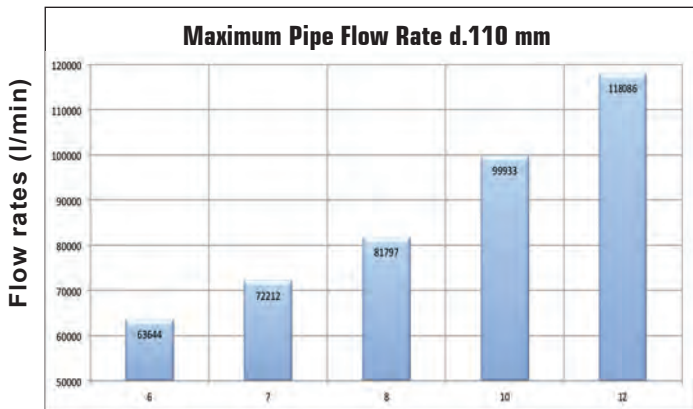

- Table 9a

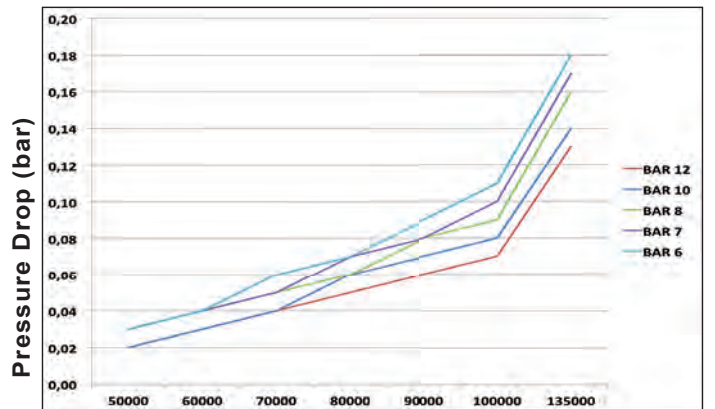

- Table 9b

Consumption lt/min

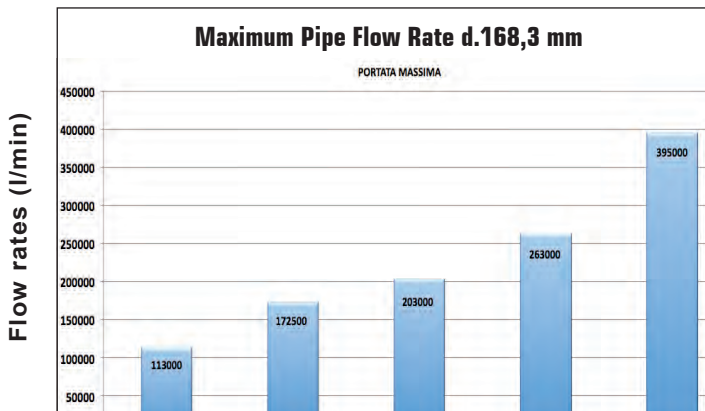

- Table 10a

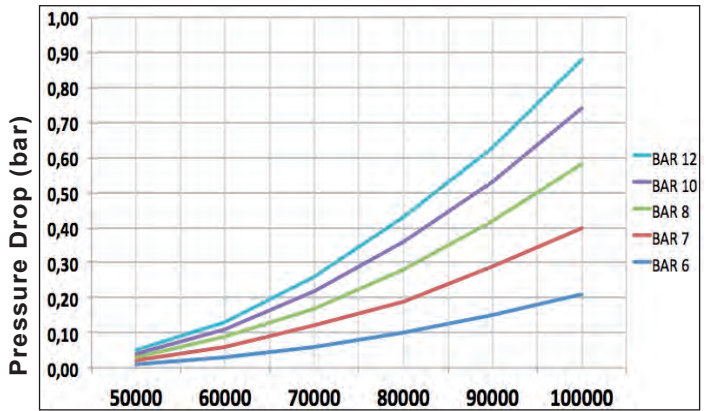

- Table 10b

Consumption lt/min

CERTIFICATIONS AND TREATMENTS - GUARANTEED FOR 10 YEARS



A TÜV certified product guarantees safety and quality. The TÜV Group issues a certificate with the results of tests carried out. This certifies the properties of products and shows the standards that apply to the tests performed.



RINA

A RINA certified product means it has high resistance to external factors. In the case of the Quick Line series, we subjected our Quick Line series products to RINA testing and also obtained certifications for fire resistance.

For further information, contact our Technical Department for the certifications dossier.



AIRCOM products have obtained special T.S.S.A. certification

(Technical Standards & Safety Authority) which sets the different standards specifically required in North America.



AIRCOM products benefit from use of the QUALICOAT brand name which certifies the quality of the paint used to provide excellent characteristics that add to the superior performance properties of our products even under particularly severe environmental operating conditions.



A QUALANOD certified product means safety as regards the process treatments it receives. In effect, the certification relates to the anodising process.

Our products have long life spans thanks to having better resistance to corrosion than our competitors' products.



The ALODINE 400 process provides pipes with an inner and outer coating. This is a titanium, chrome-free process which complies with the ROHS Directive.

Apart from protecting against oxidising, this coating provides better performance characteristics in terms of smoother surfaces inside the pipe meaning a better compressed air flow rates .

DECLARATION OF CONFORMITY AND STANDARDS

The pressurised components (AIRCOM pipes and fittings) were designed to conform with appendix VII of European Directive 97/23/CE) only as regards Article 3.3.



All the pressurised components we manufacture bear our Company name. Conformity assessments and subsequent conformity procedures stipulated by the Directive, have been applied by Aircom to products sold as individual products even if not so required by the Directive (Guide Line 1/9).

PRESSURE CURVE IN RELATION TO TEMPERATURE

The words "Ph 16" mean that AIRCOM Quick Line system products can be used at a maximum pressure of 16 bar. As temperature increases, nominal operating pressure decreases as shown in the following graphs.

PRESSURE CURVE IN RELATION TO TEMPERATURE WITH ALUMINIUM QUICK PIPE AND PA FITTINGS

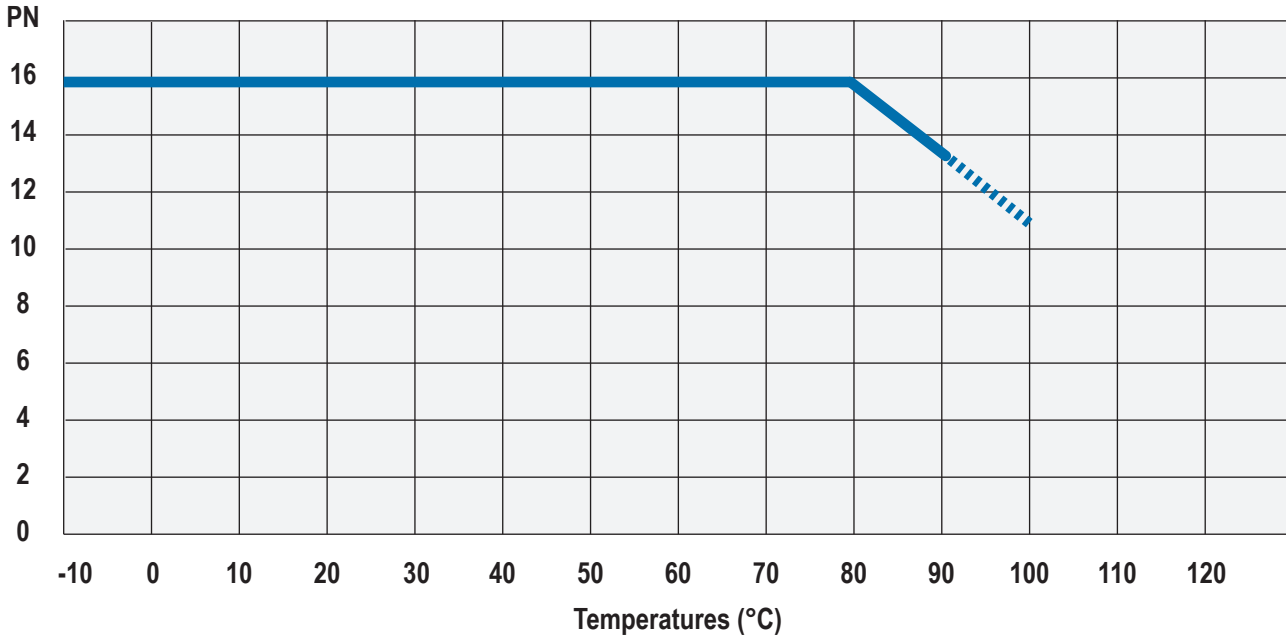

PRESSURE CURVE IN RELATION TO TEMPERATURE WITH ALUMINIUM QUICK PIPE AND ALUMINIUM FITTINGS

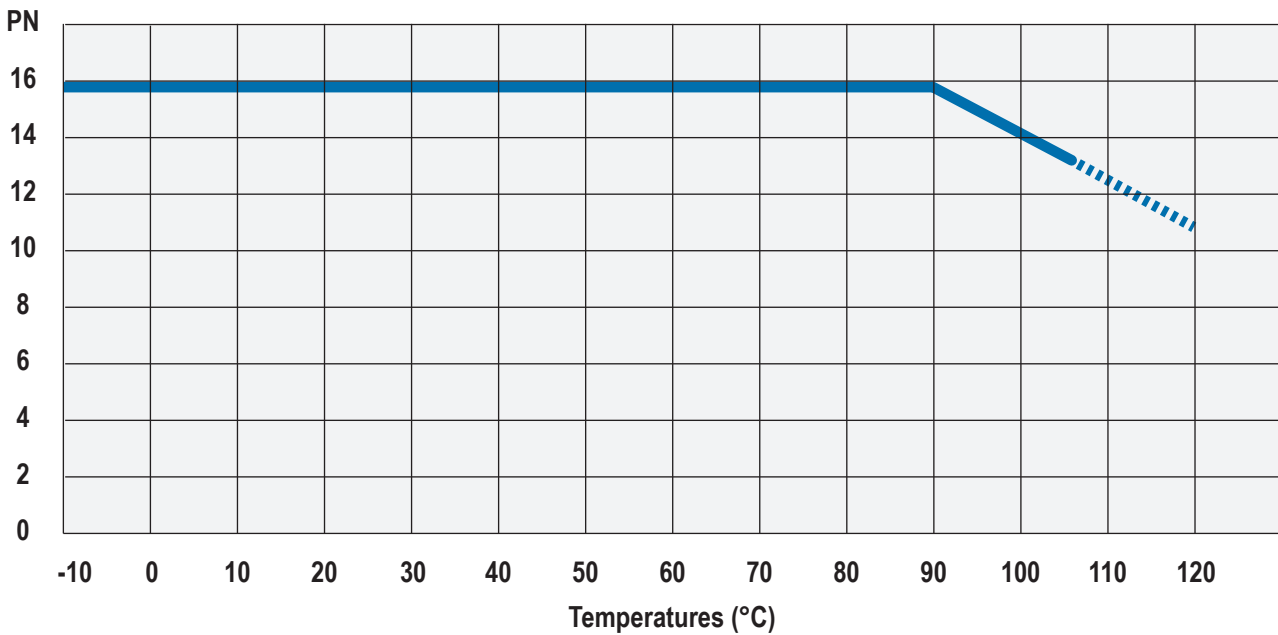

SAFETY INSTRUCTIONS



The AIRCOM system was designed to carry pressurised fluids.

Installers must follow safety procedures and comply with all requirements and local standards related to safety at work.

Installation, operating, maintenance work and repairs must be carried out by authorised, specially trained personnel as stipulated by standards and legislation.

Before carrying out any maintenance or repair work, making adjustments or non-routine controls, de-pressurise the system and cut it completely off from all sources of pressure.

Never use components that have not been approved by the manufacturer.

AIRCOM pipes and fittings are not suitable for tracked installation (wall tracking) or for underfloor use.

- Do NOT use the AIRCOM system as a support for electrical appliances or as an earthing system for other appliances or items of machinery.
- Use appropriate tools.
- Use only original spare parts.
- Technopolymer joints are sensitive to direct UV rays; if such joints are exposed, apply suitable protection. AIRCOM aluminium pipes however have excellent resistance to UV light and no precautionary measures are required.
- Never weld or bend AIRCOM pipes .
- AIRCOM pipes must be suitably protected against violent impacts.
- Before installing pipes, remove all stoppers and/or caps.
- Do NOT use solvents or chemical substances which might damage the materials from which the pipe is made.

Before installation, check the surfaces of the AIRCOM pipes (they should not have any scratches, abrasions, stains etc...).

Never connect AIRCOM pipes directly to a source of vibration; if necessary, use hoses. Before starting up the plant system, the engineer must check that it conforms with all the tests, checks and applicable standards regarding compressed air installations.

At the first start-up, bring the system to a test pressure of 1.5 bar to check for leaks or defective joints. Once the control has been carried out, gradually increase the pressure at a constant rate (max. 1 bar every 30 seconds).

The pipework must be earthed. Where polymer joints are to be used, use suitably sized copper braid to unite the banks of pipes and use two clamps to hold each bank.

AIRCOM 10-YEAR GUARANTEE

As might be expected from such a high quality product range, AIRCOM provides a 10-year guarantee against defective aluminium materials and AIRCOM joints.

Terms of cover of the guarantee:

- The use original spare parts only.
- That installation is carried out following the instructions and guide lines shown in this catalogue.
- The presence of a certificate confirming that the system has been tested.
- That components that have not been approved by the manufacturer have never been used.
- That the system is protected against impacts, vibrations and corrosive environments.
- Before making a claim, check the damaged parts and/or site conditions.
- The AIRCOM guarantee only covers the replacement of components.
- All claims must be sent to the Aircom premises at Novi Ligure (AI) and will be dealt with via standard procedures.



OUR SERVICES: project assistant, commercial service, support

AIRCOM services support our Partners throughout the plant's entire life cycle: from the initial consultancy to support during design.

Project Assistant



AIRCOM technical-commercial teams are at your disposal to study and help design your air network. Our team assist you in your project with:

- Information on the AIRCOM products and services.
- Training on how to assemble the system
- Advice on “best practice” in order to reduce your consumption of energy.
- Ongoing assistance and follow-up.
- On-site advisory presence at construction and installation locations.

Commercial Services



AIRCOM's **CUSTOMER SERVICE** teams will co-ordinate a quick response to your requirements for all information you need.

- Product availability
- Order processing and follow-up
- Delivery time-phasing and modification
- Technical information
- Design software

Contact Support



Wherever you are in the world, you can contact AIRCOM:

- by phone
- by fax
- by e-mail

should you need more information, please refer directly to your contact person in AIRCOM sales organization that you can find on AIRCOM website.

OUR SERVICE: technical training, advanced software, CAD 3D drawings

AIRCOM offers advanced training and periodic update courses for its Partners' technical personnel (designers, installers, dealers).

AIRCOM offices support Aircom Partners at every step, from the more basic plants to the highly complex systems, assisting in totally new designs as well as in revamping and additions to existing structures.

For designers and engineering depts. the complete specification of the whole Quick Line System is available on demand. If needed please refer to your sales contact.

Technical Training & Support to Designers



AIRCOM developed proprietary software to provide support in plant sizing and on site design. Thanks to this software, Aircom Partners can offer the end user a complete, efficient and personalized service.

AIRCOM Software:

- **3D drawing system:** to draw a piping plant with our components on autocad
- **APP for iOS iPad:** quotations and simple cad drawings on iPad
- **Quotation:** quote and materials lists on Windows (excel based)
- **Airtool:** plant sizing starting from end-user actual air demand
- **Flow rate calculator:** mains piping diameter sizing

Advanced Software



All AIRCOM CAD drawings are available in formats DWG and STP.
(DXF also available on demand)

Technical specifications for the AIRCOM system are available in PDF.

Technical Data Sheets are available on demand.
(pls. contact AIRCOM pertaining sales contact).

R&D and Technical Depts. provide for periodic revision of AIRCOM's technical documentation.

CAD & 3D Drawings & Technical Data Sheets



ENERGY SAVING



Over the course of the past ten years "energy management" has played an increasingly important role in the industrial sector.

This expression refers to a whole range of mechanisms and economic, management, strategic and bureaucratic factors which are now required from an industry that is heavily involved in the production of energy.

On the one hand, the price of fossil fuels is constantly increasing and weigh heavily on the costs of running a company. On the other hand, recent legislation regarding environmental protection set limits (but the tendency is towards a reduction) on pollution from power stations.

In this context, companies can find themselves in the position where they need to increase production while cutting energy costs and complying with standards.

Aircom has recently implemented a project intended to make significant energy savings by ensuring plant size calculations are correct and by the intelligent use of materials in plant systems designed for conveying compressed air. This applies to both new and existing plants and involves a detailed examination of production cycles and the use of energy.

Aircom are pleased to help designers, users and maintenance engineers by making available design, monitoring and control tools that can very quickly and accurately determine true energy requirements (kwh) in relation to the amount of compressed air needed by a user (m³/h) with a variation of plant components, or, with the same system test the efficiency of an existing plant.

The results of research have also shown that better geometrical shapes can be created, that the use of different materials for both individual and more complex components can significantly reduce running costs.

Even at a first glance, the energy savings appear to be not just beneficial but so great as to offset the cost of investing in plant equipment in just a few years.

AIRCOM ALUMINIUM PIPES
SAVINGS ON TOTAL COSTS about 30%

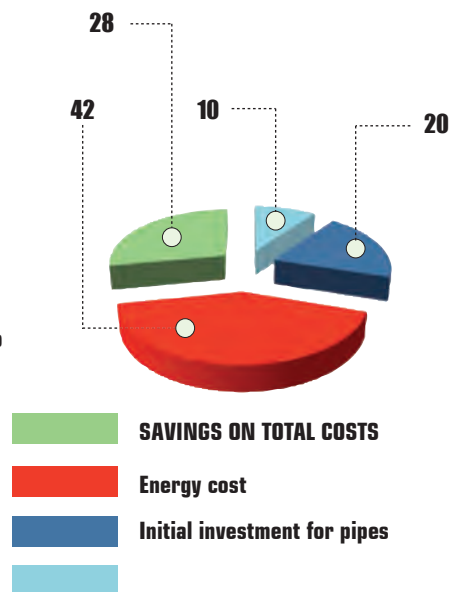

GALVANISED PIPES

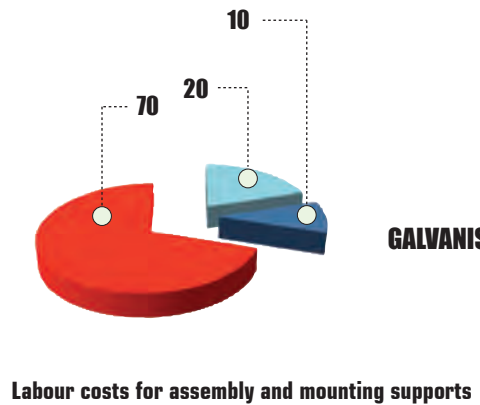

ANALYSIS OF ENERGY SAVINGS ON THE DISTRIBUTION OF COMPRESSED AIR

Plant systems of this kind are found in a very wide range of industries (in heavy and light engineering, farming etc.) where compressed air is used to operate items of equipment, machinery, tools and accessories.

An excellent distribution of pneumatic energy can be compared with network with characteristics that are similar to a cable carrying electrical energy therefore with as few leaks as possible and able to maintain:

- **pressure (minimum pressure drops caused by tightening in the pipe network)**
- **the quantity of air (absence of leaks)**
- **the quality of the air (absence of rust, dust, water, oil etc.).**

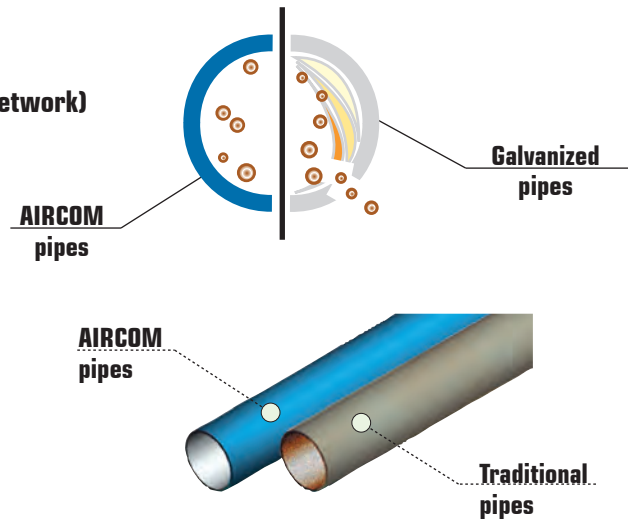

The factors which influence the overall performance of the system (from generation to end use) are mainly of 2 types: pressure drops and losses of mass (concentrated and distributed) and most attention is focussed on these.

Pressure drops are mainly caused by poor lay-outs and incorrect sizing of the distribution network in relation to variations in requirements and the generation of pneumatic energy.

Differentiated pressure levels and air treatment on the other hand play an equally important role in delivering a set quantity of compressed air.

Losses due to leaks should be identified and recorded.

An analysis of the amount of pneumatic energy produced, and of the amount needed to fulfil requirements and measurements of pressure variations in the network, allow its sizing to be evaluated, areas of waste to be identified and reconditioning work to be planned.

80% of existing distribution networks lose pneumatic energy with many waste levels of up to 50%.

COMPRESSED AIR DISTRIBUTION COSTS

in a traditional plant system

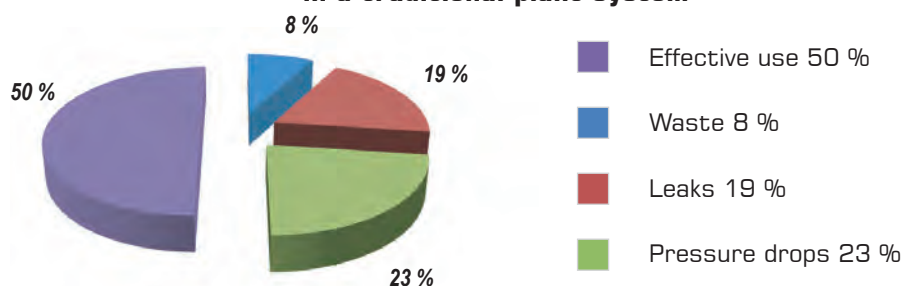



AIR IS OUR FUTURE

AIRCOM s.r.l.

Via Trattato di Maastricht
15067 Novi Ligure (AL) - ITALY
Ph. +39 0143 329502
Fax +39 0143 358175

www.aircomsystem.com
info@aircomsystem.com